

# 48V/700W Switch Mode Battery Charger

*Pre-Release Datasheet*

*Specifications are subject to change without notice.*

# SUMMIT™ SERIES

By: *Lester*  *Electrical*



## **High Efficiency ▪ Leading Charge Algorithms ▪ High Reliability**

### **Off-Board or On-Board Charging**

The Lester Electrical Summit Series 48V/700W switch mode battery charger (SMBC) is designed both for off-board (shelf) and on-board (built-in) use. It features intelligent natural convection cooling (no fan) and high energy efficiency, which enables it to be used in thermally demanding applications.

### **High Efficiency: > 90% Average, > 92% Peak**

The Summit Series 48V/700W SMBC features high AC-to-DC conversion efficiency of > 90% average across a full charge cycle and > 92% peak, including all losses from AC plug to DC connector. The charger, when paired with batteries, exceeds the applicable requirements of the California Energy Commission (CEC) Appliance Efficiency Regulations for Battery Charger Systems. It also features a high AC power factor near unity.

### **Sealed and High Reliability: IP66, > 150,000 Hours MTBF**

The heavy-duty aluminum enclosure is sealed with an IP66, NEMA 4 rating to protect the charger from ingress of water, dust, and other environmental elements. The rugged/durable charger has been designed and tested for the shock and vibration conditions that occur with on-board use. It has also been designed to provide the high reliability that is expected of a Lester Electrical product with an MTBF reliability rating of > 150,000 hours. Additionally, the charger includes a hardware watchdog timer for high uptime operation.

### **Leading Charge Algorithms: Featuring Progressive DV/DT™**

An advanced microprocessor controller is featured in the charger. Precise Lester Electrical charging and termination algorithms, included patent-pending Progressive DV/DT, prevent both undercharging and overcharging, optimizing both daily battery capacity and overall battery life.

### **Flexible Battery Types: Wet, AGM, Gel, Lithium-Ion**

This Summit Series charger includes industry-leading and field-proven wet/flooded, AGM, and gel deep-cycle lead-acid battery charge profiles. It can also be configured with battery specific, application specific, or custom charge profiles, including lithium-ion chemistries, such as lithium iron phosphate (LFP). Using the externally accessible communication port, a LE programming module or laptop/PC can be used to update the charge profiles in the field and change the active profile.

### **Universal AC Input**

The charger includes a universal AC input and operates at 85-270 Vac and 45-65 Hz for use anywhere in the world. The IEC 60320 C14 AC inlet enables the charger to be paired with an AC cord with the appropriate localized plug.

### **Vehicle Lockout/Interlock and DC Disconnect Sense**

The available lockout/interlock control output can be used to prevent vehicle/equipment operation when the charger has AC power available or when the DC plug is connected to the vehicle with a supported DC connector configuration. The charger also features patented DC disconnect sense functionality when paired with a supported DC connector configuration to minimize charger output inhibit time when a DC disconnect occurs during charging.

### **Safety and Regulatory Approvals**

The charger will be UL listed/recognized, cUL/CSA listed/recognized, and CE certified. It will include applicable EN and FCC approvals. The charger will also be certified compliant with the CEC Appliance Efficiency Regulations for Battery Charger Systems using the in-house Lester Electrical CEC efficiency regulations test system.

# 48V/700W Switch Mode Battery Charger

## SPECIFICATIONS

### AC Input

Voltage range, rated	100-230 Vac
Voltage range, operating	90-264 Vac (< 100 Vac: reduced power)
Frequency, rated	50-60 Hz
Frequency, operating	45-65 Hz
Phase	Single-phase
Current, maximum	8 A
Efficiency	> 90% average, full charge cycle; > 92% peak; AC plug to DC connector
Power factor	> 0.98, 120 Vac; > 0.95, all AC input voltages
Protection	Current limit, surge, transient, under voltage

### DC Output

Voltage, nominal	48 Vdc
Voltage, maximum	72 Vdc
Voltage, min start-up	10 Vdc
Power	700 W
Current, rated	13 A
Current, maximum	14.5 A
Battery types	Wet/flooded, AGM, gel deep-cycle lead-acid; lithium iron phosphate (LFP); custom
Protection	Current limit, short circuit, reverse polarity, under voltage, over voltage, wrong batt voltage

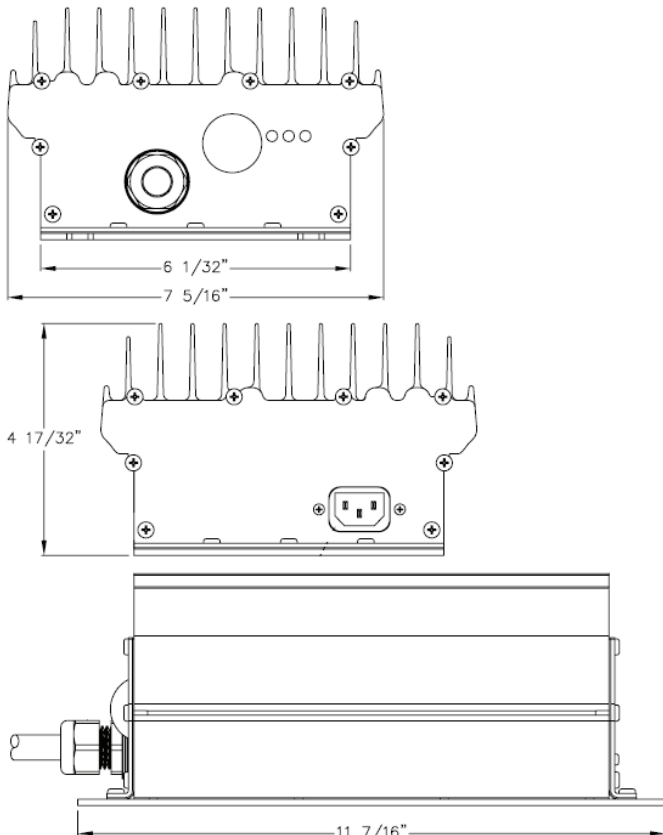

### LEDs

Charge Complete (green),  
Charge Status (yellow),  
Fault (red)

### Lockout Control

Pulls down to battery neg (-)  
when active (250 mA, max)

### Battery Temp Sensor

Optional

### Mechanical

Dimensions (LxWxH)	11.438 x 7.313 x 4.532 in (291 x 186 x 116 mm)
Weight (approx)	9.0 lbs (4.1 kg)
Cooling	Natural convection (no fan)
AC connector	IEC 60320 C14 inlet with optional cord clamp
DC cable/connector	Variety available
Lockout cable/connector	Variety available
Mounting	Shelf, wall, bulkhead, threaded steel rod/hook
Handle	Optional

### Environmental

Enclosure rating	IP66, NEMA 4
Operating temperature	-25 °C to 60 °C (-13 °F to 140 °F) (> 40 °C: reduced power)
Storage temperature	-40 °C to 85 °C (-40 °F to 185 °F)

### Reliability

> 150,000 hours MTBF at full output at 25 °C  
(Telcordia SR-332, MIL-STD-267)

### Safety/Regulatory (Pending)

UL listed/recognized; cUL/CSA listed/recognized; CE certified;  
EN safety, emissions, immunity; FCC Part 15; CEC Appliance  
Efficiency Regulations, Title 20

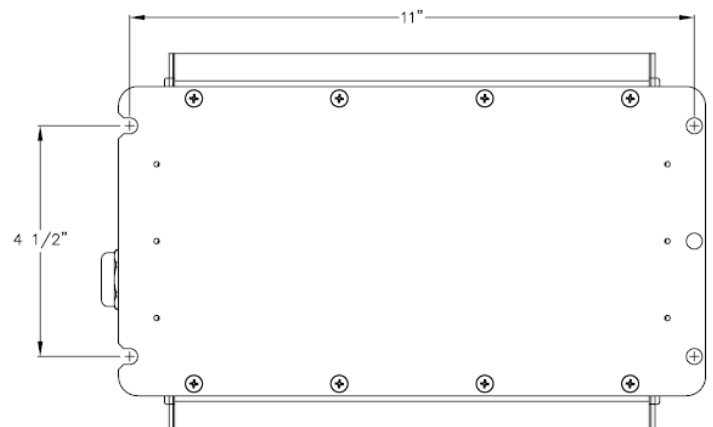

625 West A Street F: 402.474.1769  
Lincoln, NE 68522 Sales@LesterElectrical.com  
P: 402.477.8988 LesterElectrical.com

Specifications are subject to change without notice.

Document ID: SM7003.3

Copyright © 2012 Lester Electrical of Nebraska, Inc. All rights reserved.

